

Installation Note

Reference Mixer Transfer Switch Upgrade Kit

For E8363B and E8364B PNA Series Microwave Network Analyzers

Network Analyzer Model Number	Upgrade Kit Part Number
E8363B and E8364B	E8364-60107



Agilent Part Number: E8364-90024

Printed in USA September 2007

Supersedes print date: January 2005

© Agilent Technologies, Inc. 2002, 2005, 2007

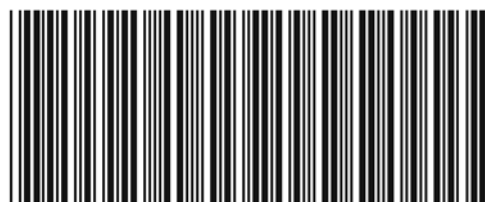

E8364-90024

WARRANTY STATEMENT

THE MATERIAL CONTAINED IN THIS DOCUMENT IS PROVIDED “AS IS,” AND IS SUBJECT TO BEING CHANGED, WITHOUT NOTICE, IN FUTURE EDITIONS. FURTHER, TO THE MAXIMUM EXTENT PERMITTED BY APPLICABLE LAW, AGILENT DISCLAIMS ALL WARRANTIES, EITHER EXPRESS OR IMPLIED WITH REGARD TO THIS MANUAL AND ANY INFORMATION CONTAINED HEREIN, INCLUDING BUT NOT LIMITED TO THE IMPLIED WARRANTIES OF MERCHANTABILITY AND FITNESS FOR A PARTICULAR PURPOSE. AGILENT SHALL NOT BE LIABLE FOR ERRORS OR FOR INCIDENTAL OR CONSEQUENTIAL DAMAGES IN CONNECTION WITH THE FURNISHING, USE, OR PERFORMANCE OF THIS DOCUMENT OR ANY INFORMATION CONTAINED HEREIN. SHOULD AGILENT AND THE USER HAVE A SEPARATE WRITTEN AGREEMENT WITH WARRANTY TERMS COVERING THE MATERIAL IN THIS DOCUMENT THAT CONFLICT WITH THESE TERMS, THE WARRANTY TERMS IN THE SEPARATE AGREEMENT WILL CONTROL.

DFARS/Restricted Rights Notice

If software is for use in the performance of a U.S. Government prime contract or subcontract, Software is delivered and licensed as “Commercial computer software” as defined in DFAR 252.227-7014 (June 1995), or as a “commercial item” as defined in FAR 2.101(a) or as “Restricted computer software” as defined in FAR 52.227-19 (June 1987) or any equivalent agency regulation or contract clause. Use, duplication or disclosure of Software is subject to Agilent Technologies’ standard commercial license terms, and non-DOD Departments and Agencies of the U.S. Government will receive no greater than Restricted Rights as defined in FAR 52.227-19(c)(1-2) (June 1987). U.S. Government users will receive no greater than Limited Rights as defined in FAR 52.227-14 (June 1987) or DFAR 252.227-7015 (b)(2) (November 1995), as applicable in any technical data.

Safety Notes

The following safety notes are used throughout this document. Familiarize yourself with each of these notes and its meaning before performing any of the procedures in this document.

WARNING	Warning denotes a hazard. It calls attention to a procedure which, if not correctly performed or adhered to, could result in injury or loss of life. Do not proceed beyond a warning note until the indicated conditions are fully understood and met.
----------------	---

CAUTION	Caution denotes a hazard. It calls attention to a procedure that, if not correctly performed or adhered to, could result in damage to or destruction of the instrument. Do not proceed beyond a caution sign until the indicated conditions are fully understood and met.
----------------	---

Contacting Agilent

Assistance with test and measurements needs and information on finding a local Agilent office are available on the Web at:

www.agilent.com/find/assist

If you do not have access to the Internet, please contact your Agilent field engineer.

NOTE In any correspondence or telephone conversation, refer to the Agilent product by its model number and full serial number. With this information, the Agilent representative can determine whether your product is still within its warranty period.

About Installing the Upgrade Kit

IMPORTANT Option 081 can only be installed on analyzers with the option combinations listed below as “Products affected”. If your analyzer does not have the proper options (as listed below), it will be necessary to install those options **BEFORE** installing this option (Option 081).

Products affected	E8363B and E8364B; all option combinations that include Option 014
Installation to be performed by	Agilent service center or personnel qualified by Agilent
Estimated installation time	1.5 hours
Estimated adjustment time	0.5 hours
Estimated full instrument calibration time	4.5 hours

Description of the Option 081 Reference Mixer Transfer Switch Upgrade

This upgrade adds two high-speed microwave switches in the reference (R1) channel of the PNA. These switches are used to switch a reference mixer in and out of the reference channel signal path during calibration and measurement. This allows the user to easily switch between standard S-parameter (non-frequency-offset) measurements and frequency offset measurements that require an external reference mixer.

Items Included in the Upgrade Kit

Check the contents of your kit against this list. If any item is missing or damaged, contact Agilent Technologies. Refer to “[Contacting Agilent](#)” on page 3.

Table 1 Contents of the Upgrade Kit (E8364-60107)

Ref. Desig.	Description	Qty	Part Number
These parts are for all analyzer options			
	Installation note (this document)	1	E8364-90024
	Machine screw, M3.0 x 6, TORX T-10 (for attaching switch bracket)	2	0515-0430
	Machine screw, M3.0 x 12, TORX T-10 (for attaching A45 and A46 reference switches)	8	0515-0664
	Switch bracket	1	E8364-00012
A23	Detector	1	5087-7242
A45, A46	Reference switch	2	5087-7238
	Wiring harness, two conductors (for A45 and A46 switches)	2	8121-0966
W95	RF cable, A46 reference switch to A23 channel R1 detector	1	E8364-20119
W96	RF cable, A45 reference switch to A46 reference switch	1	E8364-20127
W97	RF cable, A46 reference switch to REFERENCE 1 SOURCE OUT	1	E8364-20121
W98	RF cable, A45 reference switch to REFERENCE 1 RCVR R1 IN	1	E8364-20123
These parts are for analyzers WITH Options 014 and 080 but WITHOUT Options UNL and 016			
W67	RF cable, A25 test port 1 coupler to PORT 1 CPLR ARM	1	E8364-20156
W68	RF cable, A26 test port 2 coupler to PORT 2 CPLR ARM	1	E8364-20157
W71	RF cable, REFERENCE 2 RCVR R2 IN to A29 channel R2 mixer	1	E8364-20153
W99	RF cable, A45 reference switch to A28 channel R1 mixer	1	E8364-20152
These parts are for analyzers WITH Options UNL, 014, and 080 but WITHOUT Option 016			
W71	RF cable, REFERENCE 2 RCVR R2 IN to A29 channel R2 mixer	1	E8364-20155
W99	RF cable, A45 reference switch to A28 channel R1 mixer	1	E8364-20154
This part is for analyzers with Options UNL, 014, 016, and 080			
W99	RF cable, A45 reference switch to A28 channel R1 mixer	1	E8364-20125

Installation Procedure for the Upgrade Kit

The network analyzer must be in proper working condition prior to installing this option. Any necessary repairs must be made before proceeding with this installation.

WARNING **This installation requires the removal of the analyzer’s protective outer covers. The analyzer must be powered down and disconnected from the mains supply before performing this procedure.**

Electrostatic Discharge Protection

Protection against electrostatic discharge (ESD) is essential while removing or connecting cables or assemblies within the network analyzer.

Static electricity can build up on your body and can easily damage sensitive internal circuit elements when discharged. Static discharges too small to be felt can cause permanent damage. To prevent damage to the instrument:

- *always* wear a grounded wrist strap having a 1 M Ω resistor in series with it when handling components and assemblies.
- *always* use a grounded, conductive table mat while working on the instrument.
- *always* wear a heel strap when working in an area with a conductive floor. If you are uncertain about the conductivity of your floor, wear a heel strap.
- *always* ground yourself before you clean, inspect, or make a connection to a static-sensitive device or test port. You can, for example, grasp the grounded outer shell of the test port or cable connector briefly.

Figure 1 shows a typical ESD protection setup using a grounded mat and wrist strap. Refer to “Tools and Equipment Required for the Installation” on page 6 for part numbers.

Figure 1 **ESD Protection Setup**

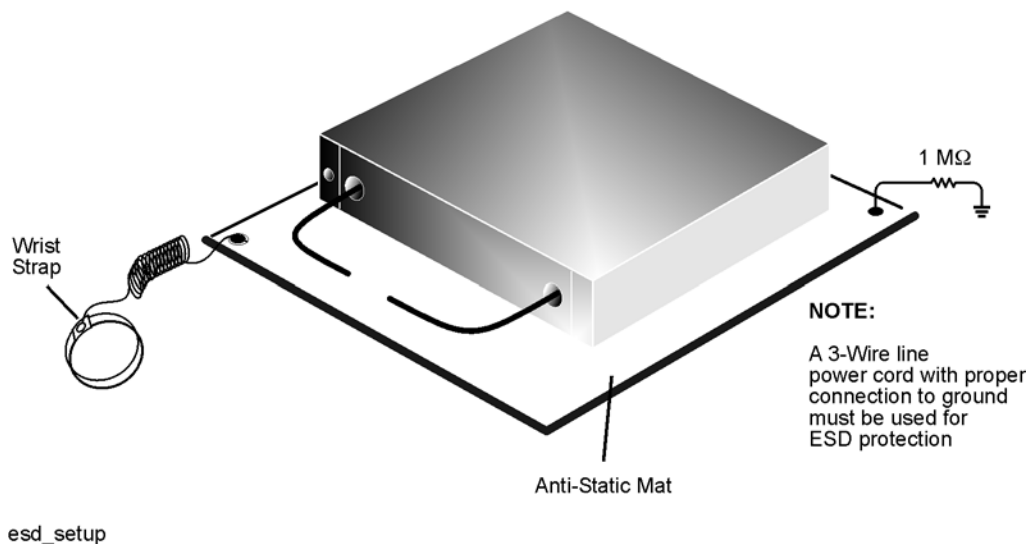

Overview of the Installation Procedure

Step 1. Remove the Outer Cover.

Step 2. Remove the Front Panel Assembly.

Step 3. Raise the Receiver Deck.

Step 4. Remove the Existing Cables.

Step 5. Replace the A23 Channel R1 Detector.

Step 6. Install the Option 081 Reference Switches.

Step 7. Install the Option 081 Cables.

Step 8. Reinstall the Test Port 1 Coupler and the Receiver Attenuator.

Step 9. Lower and Secure the Receiver Deck.

Step 10. Reinstall the Front Panel Assembly and Front Panel Jumpers.

Step 11. Reinstall the Outer Cover.

Step 12. Enable Option 081.

Step 13. Perform Post-Upgrade Adjustments and Calibration.

Tools and Equipment Required for the Installation

Description	Qty	Agilent Part Number
T-10 TORX driver (set to 9 in-lbs)	1	N/A
T-20 TORX driver (set to 21 in-lbs)	1	N/A
5/16-inch torque wrench (set to 10 in-lbs)	1	N/A
5/16-inch torque wrench (set to 21 in-lbs)	1	N/A
1-inch torque wrench (set to 72 in-lbs)	1	N/A
ESD grounding wrist strap	1	9300-1367
5-ft grounding cord for wrist strap	1	9300-0980
2 x 4 ft conductive table mat and 15-ft grounding wire	1	9300-0797
ESD heel strap (for use with conductive floors)	1	9300-1308

CAUTION Use a 5/16-inch torque wrench set to 10 in-lbs on all cable connections except the front-panel connectors to which the front-panel jumpers attach (Option 014). Use a 5/16-inch torque wrench set to 21 in-lbs for these connections.

Equipment Required for Post-Upgrade Adjustments

Equipment Type	Model or Part Number	Alternate Model or Part Number
Power meter	E4418B/E4419B	E4418A/E4419A
Power sensor, 2.4 mm	8487A	None
Adapter, 2.4 mm (f) to 2.4 mm (f)	11900B	85056-60007
RF cable, 2.4 mm (f) to 2.4 mm (f)	85133C	85133E

Step 1. Remove the Outer Cover

CAUTION This procedure is best performed with the analyzer resting on its front handles in the vertical position. *Do not place the analyzer on its front panel without the handles.* This will damage the front panel assemblies.

Refer to [Figure 2](#) for this procedure.

1. Disconnect the power cord (if it has not already been disconnected).
2. With a T-20 TORX driver, remove the four rear panel feet (item ①) by removing the center screws (item ②).
3. Slide the four bottom feet (item ③) off the cover.
4. With a T-20 TORX driver, remove the strap handles (item ④) by loosening the screw (item ⑤) on each end until the handle is free of the analyzer.
5. Slide the cover off of the frame.

Figure 2 Outer Cover Removal

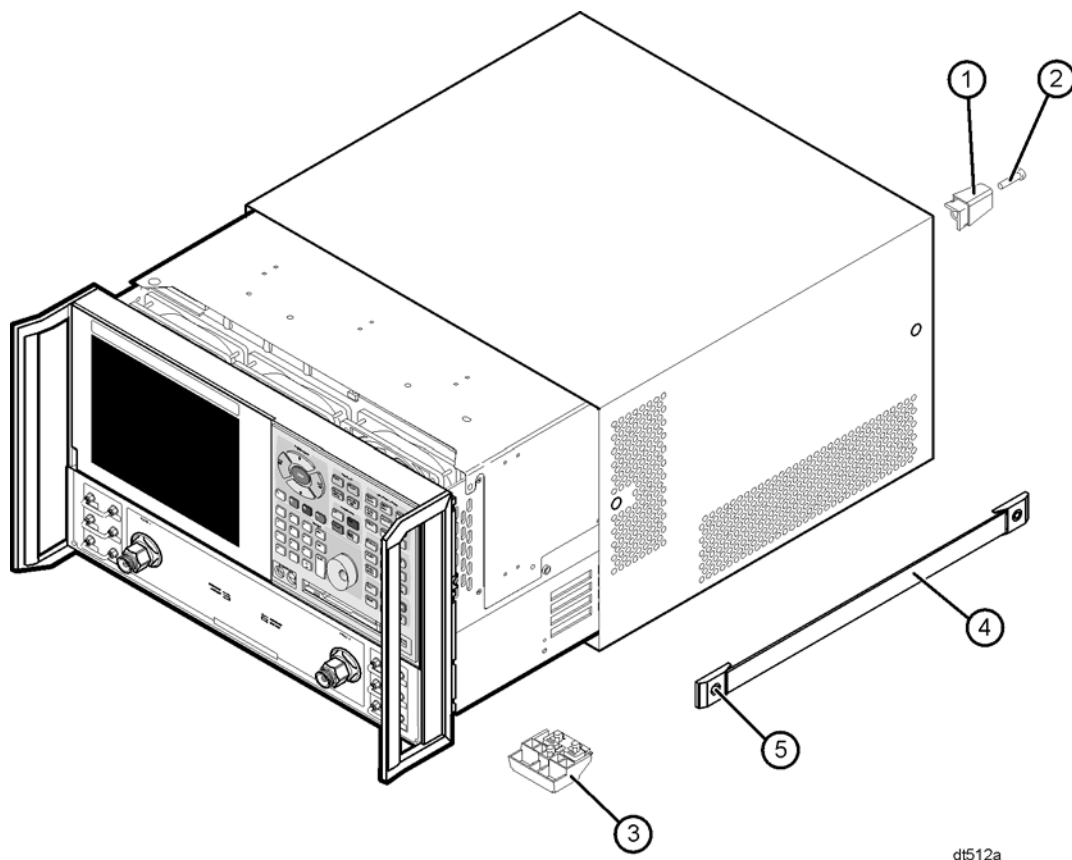

dt512a

Step 2. Remove the Front Panel Assembly

Refer to [Figure 3](#) for this procedure.

1. With a 5/16-inch wrench, remove the six front panel semirigid jumper cables (item ①).
2. With a T-10 TORX driver, remove the eight screws (item ②) from the sides of the frame.

CAUTION Before removing the front panel from the analyzer, lift and support the front of the analyzer chassis.

3. Slide the front panel over the test port connectors.
4. Disconnect the front panel interface ribbon cable (item ③) from the A3 front panel interface board. The front panel is now free from the analyzer.

Figure 3 Front Panel Assembly Removal

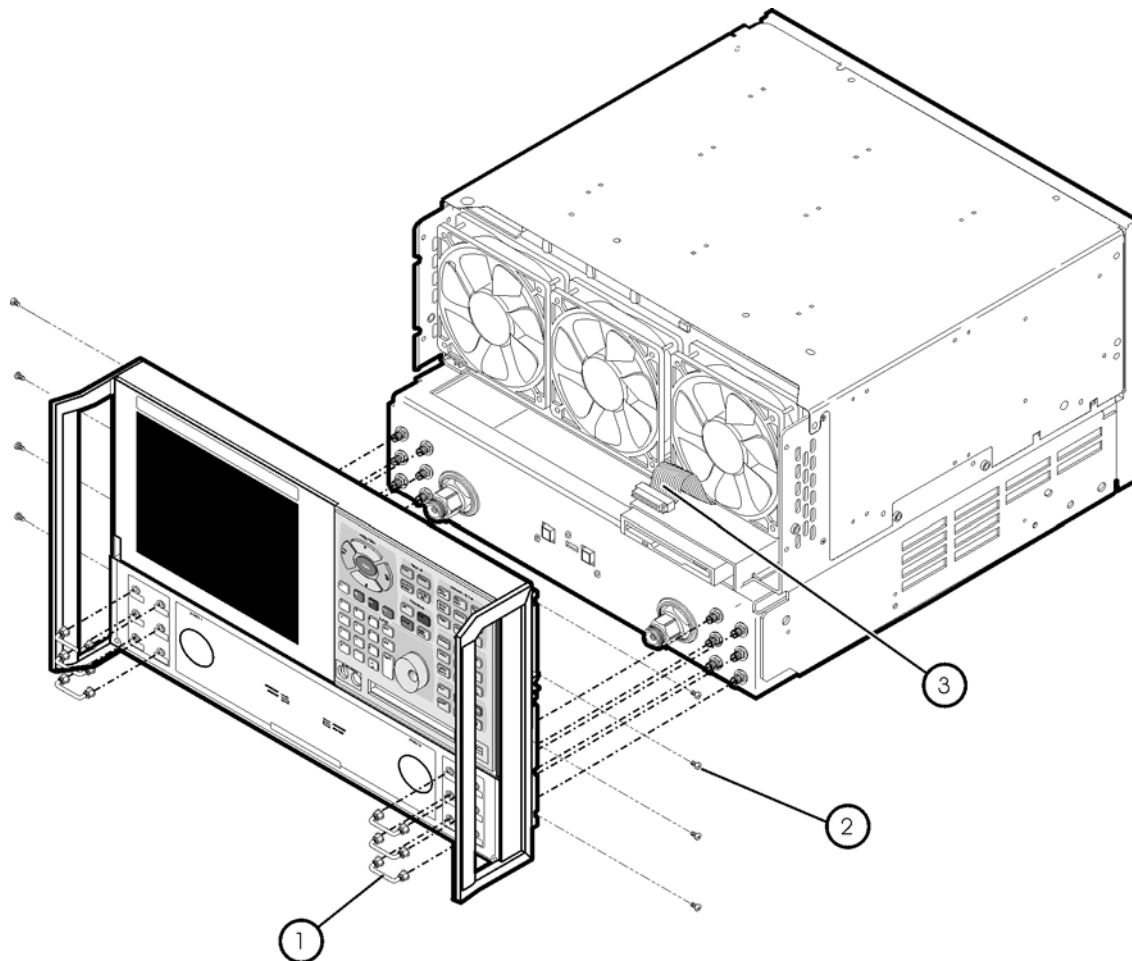

st536a

Step 3. Raise the Receiver Deck

Refer to [Figure 4](#) for this procedure.

1. Place the analyzer bottom-side up on a flat surface.
2. With a T-10 TORX driver, remove the four screws, (item ①), that secure the receiver deck.
3. Pull the latch pin (item ②) towards the other side of the analyzer to release the receiver deck.
4. Lift the receiver deck to partially raise it, then release the latch pin (item ②). Lift the receiver deck to its fully raised position and ensure that the latch pin latches in the raised position.

Figure 4 Receiver Deck Raising

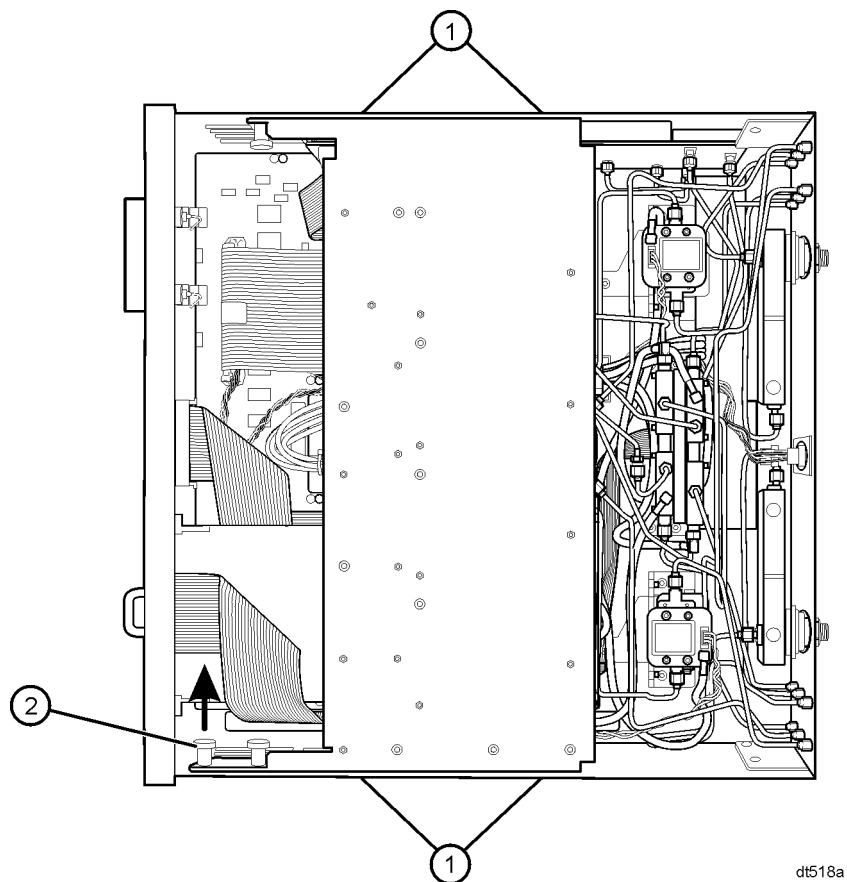

Step 4. Remove the Existing Cables

Analyzers with Hardware Options 014 and 080 Only

Refer to [Figure 5](#) for this portion of the procedure.

Remove the following cables.

- W65 E8364-20047 A23 channel R1 detector to REFERENCE 1 SOURCE OUT
- W67 E8364-20043 A25 test port 1 coupler to PORT 1 CPLR ARM
- W68 E8364-20044 A26 test port 2 coupler to PORT 2 CPLR ARM
- W70 E8364-20075 REFERENCE 1 RCVR R1 IN to A28 channel R1 mixer
- W71 E8364-20076 REFERENCE 2 RCVR R2 IN to A29 channel R2 mixer

Figure 5 Cable Removal, Analyzers with Options 014 and 080

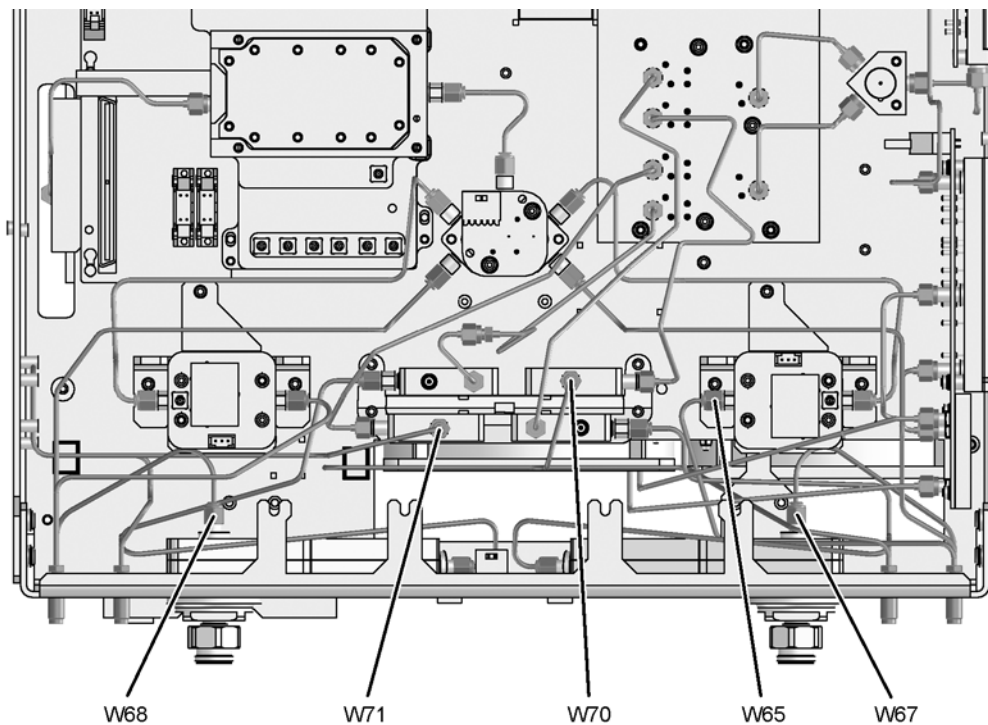

8364_024_01

Analyzers with Hardware Options UNL, 014, and 080 Only

Refer to [Figure 6](#) for this portion of the procedure.

Remove the following cables.

- W65 E8364-20047 A23 channel R1 detector to REFERENCE 1 SOURCE OUT
- W70 E8364-20176 REFERENCE 1 RCVR R1 IN to A28 channel R1 mixer
- W71 E8364-20177 REFERENCE 2 RCVR R2 IN to A29 channel R2 mixer

Figure 6 Cable Removal, Analyzers with Options UNL, 014, and 080

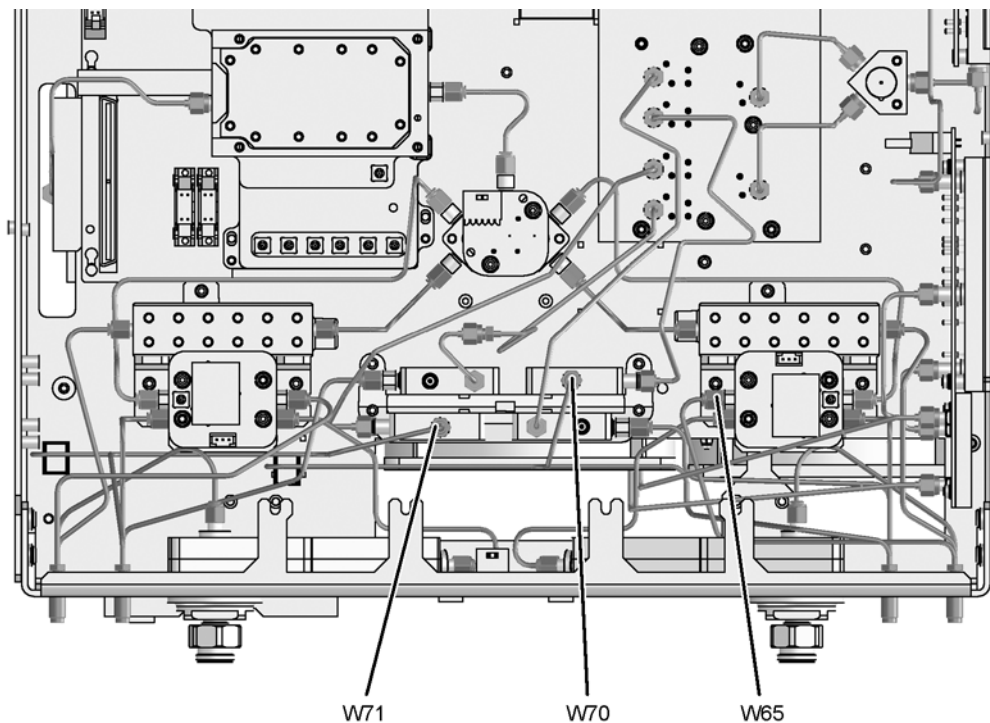

8364_024_02

Analyzers with Hardware Options UNL, 014, 016, and 080

Refer to [Figure 7](#) for this portion of the procedure.

Remove the following cables.

- W65 E8364-20047 Channel R1 detector to REFERENCE 1 SOURCE OUT
- W70 E8364-20151 REFERENCE 1 RCVR R1 IN to A28 channel R1 mixer

Figure 7 Cable Removal, Analyzers with Options UNL, 014, 016, and 080

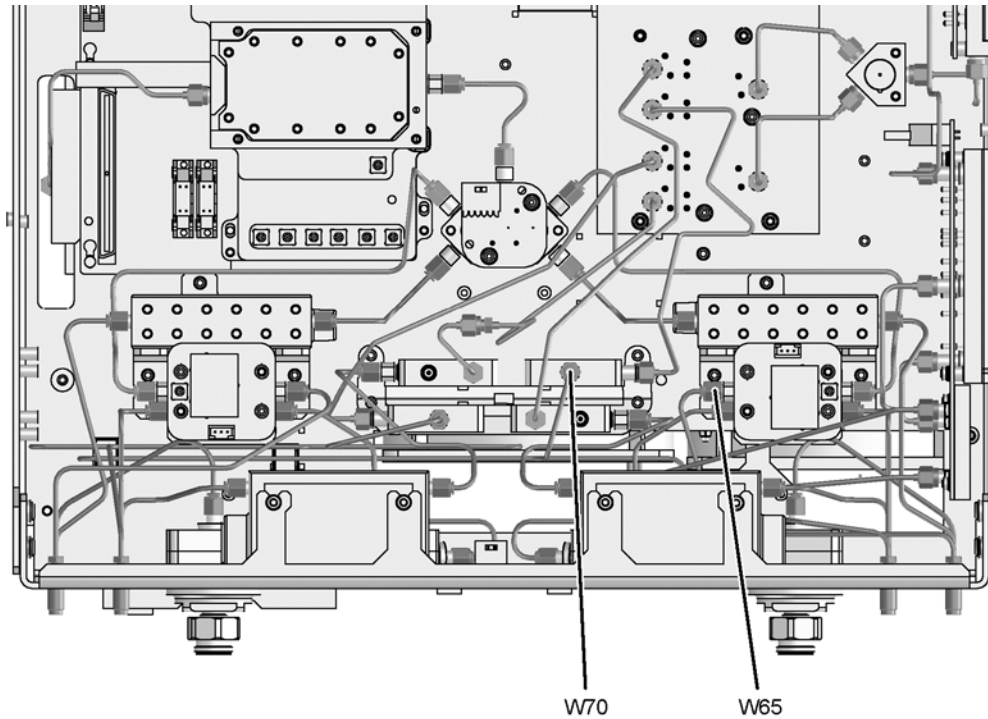

8364_024_03

Step 5. Replace the A23 Channel R1 Detector

Refer to [Figure 8](#) for this the procedure. The new parts referenced in this procedure are listed in [Table 1](#) on page 4.

1. Using a 5/16-inch wrench, disconnect cable W3 from the A23 channel R1 detector.
2. Disconnect the stranded control cable (item ①) and the flexible RF cable (item ②) from the detector.
3. With a T-10 TORX driver, remove the two mounting screws (item ③) and remove the detector from the analyzer.
4. Place the new detector (provided) into position. With a T-10 TORX driver, install the two mounting screws (item ③) to secure the detector.
5. Using a 5/16-inch torque wrench, connect cable W3 to the new detector.
6. Reconnect the stranded control cable (item ①) and the flexible RF cable (item ②) to the new detector.

Figure 8 Channel R1 Detector Replacement

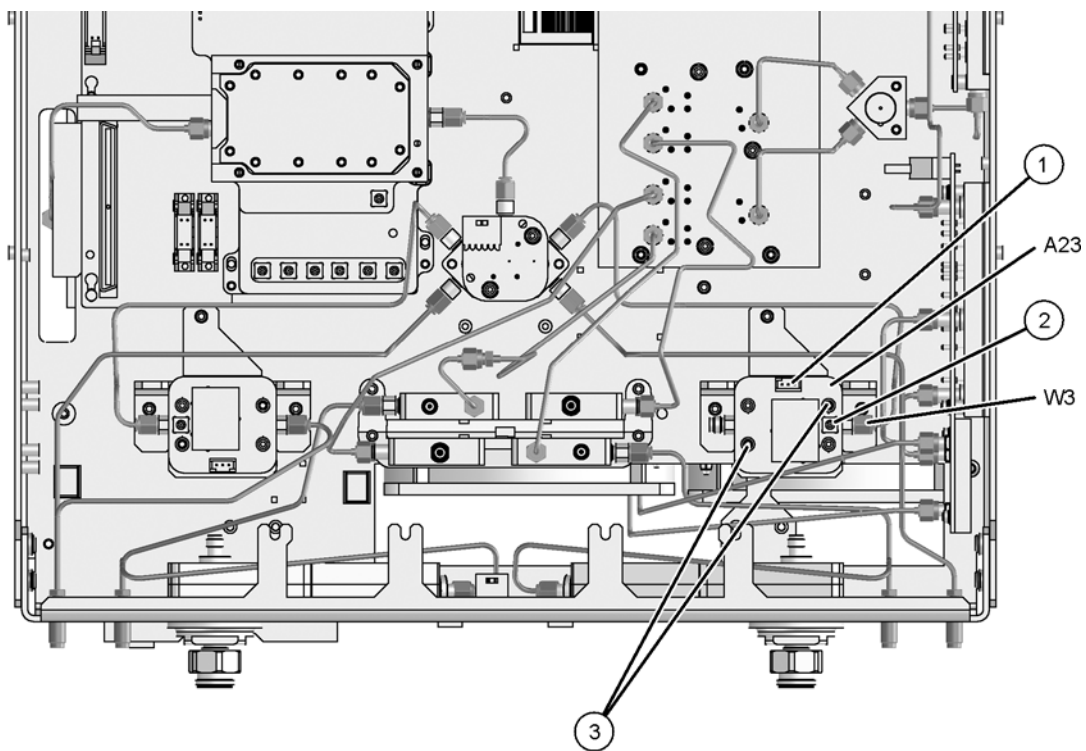

8364_024_04

Step 6. Install the Option 081 Reference Switches

Install the A45 Reference Switch

Refer to [Figure 9](#) for this procedure. The new parts referenced in this procedure are listed in [Table 1](#) on page 4.

1. Attach one of the reference switches (provided) to the mounting bracket (item ①) (provided) using four M3.0 x 12 screws (provided).
2. Insert the bracket, with the A45 reference switch attached, into the location shown.
3. With a T-10 TORX driver, install two M3.0 x 6 mounting screws (item ②) (provided) in the bracket to secure it to the test set deck.

Figure 9 A45 Reference Switch Installation

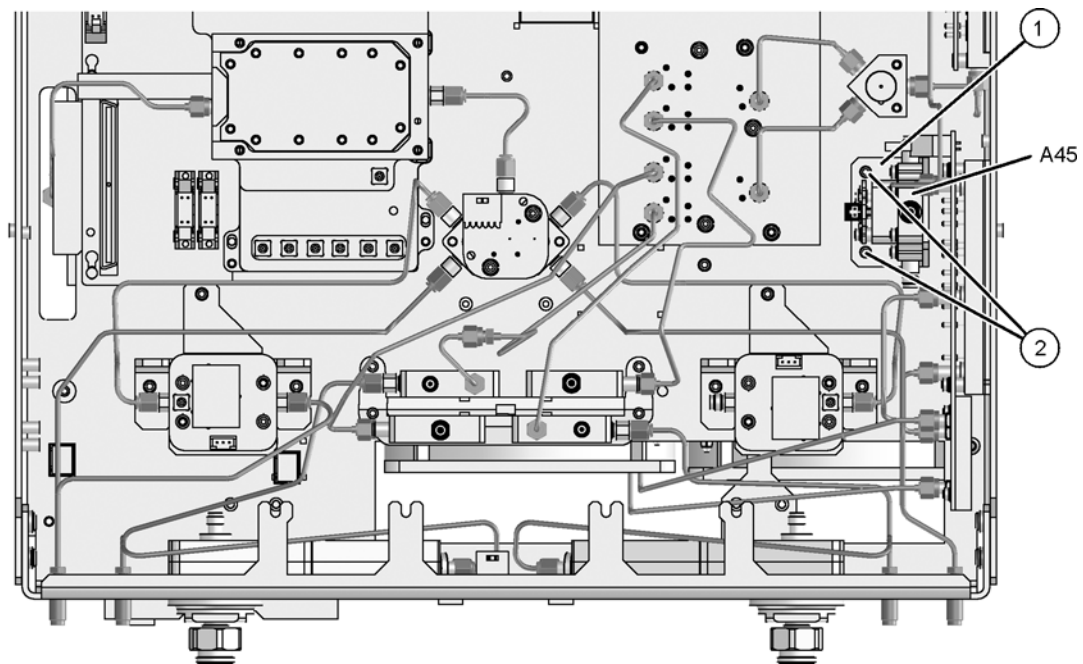

8364_024_05

Install the A46 Reference Switch

Refer to [Figure 10](#) for this procedure. The new parts referenced in this procedure are listed in [Table 1](#) on page 4.

Before the A46 reference switch can be installed, the A25 test port 1 coupler and the A43 channel A receiver attenuator (Option 016 only) must be removed.

1. Option 016 only. Remove the A43 channel A receiver attenuator:
 - a. Using a 5/16-inch wrench, disconnect the semirigid cables (item ①) and (item ②).
 - b. With a T-10 TORX driver, loosen the two mounting screws (item ③) and slide the attenuator toward the rear of the analyzer to remove it from the mounting tabs.
 - c. Disconnect the ribbon cable from the attenuator and set the attenuator aside for reinstallation later.
2. Remove the A25 test port 1 coupler:
 - a. Using a 5/16-inch wrench, disconnect the semirigid cables (item ④) and (item ⑤), if not previously removed.
 - b. Using a 1-inch wrench remove the coupler nut (item ⑥).
 - c. Remove the test port coupler from the analyzer and set it aside for reinstallation later.
3. Place the A46 reference switch (provided) into position and, with a T-10 TORX driver, install four M3.0 x 12 mounting screws (provided) to secure it to the test set deck.

Figure 10 A46 Reference Switch Installation

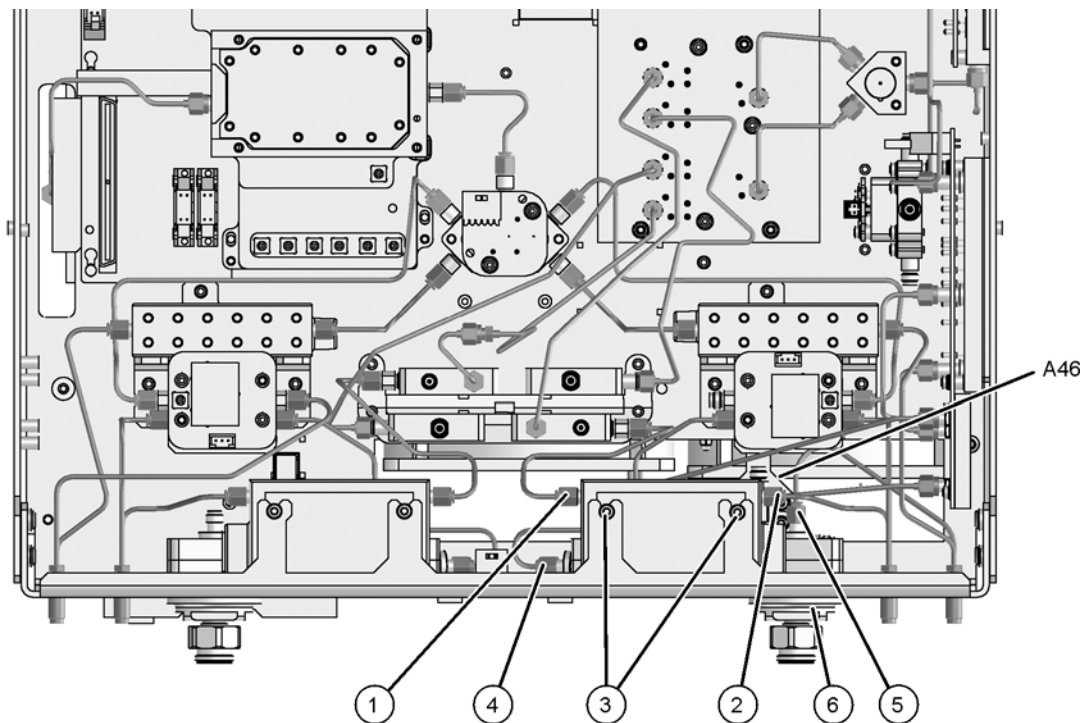

8364_024_06

Step 7. Install the Option 081 Cables

Analyzers with Hardware Options 014 and 080 Only

Refer to [Figure 11](#) for this portion of the procedure. The new parts referenced in this procedure are listed in [Table 1 on page 4](#).

Install the following cables (provided) **in the order listed**.

- Wire harness 8121-0966 A45 reference switch ① to A16 test set motherboard J31
- Wire harness 8121-0966 A46 reference switch ② to A16 test set motherboard J30
- W96 E8364-20127 A45 reference switch to A46 reference switch
- W97 E8364-20121 A46 reference switch to REFERENCE 1 SOURCE OUT
- W98 E8364-20123 A45 reference switch to REFERENCE 1 RCVR R1 IN
- W99 E8364-20152 A45 reference switch to A28 channel R1 mixer
- W95 E8364-20119 A46 reference switch to A23 channel R1 detector
- W68 E8364-20157 A26 test port 2 coupler to PORT 2 CPLR ARM
- W71 E8364-20153 REFERENCE 2 RCVR R2 IN to A29 channel R2 mixer

Figure 11 Cable Installation, Analyzers with Options 014 and 080

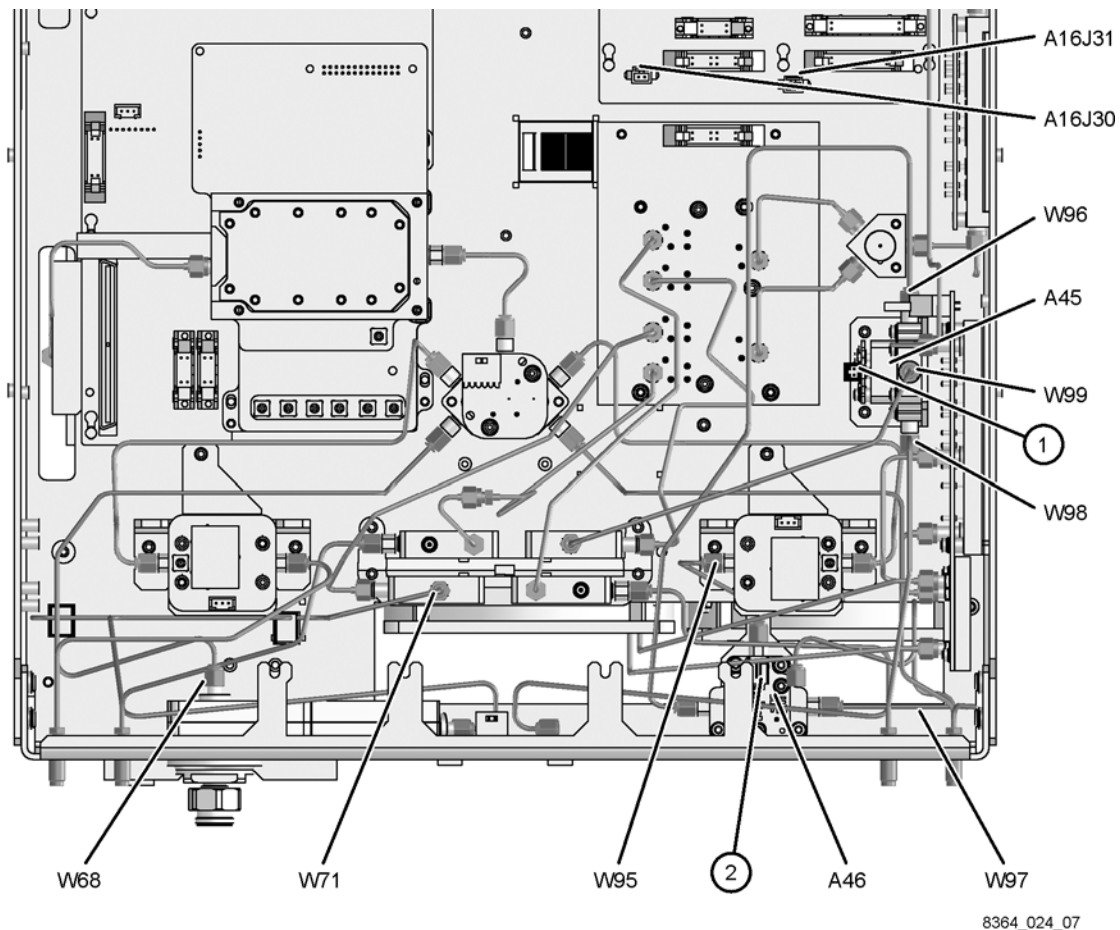

Analyzers with Hardware Options UNL, 014, and 080 Only

Refer to [Figure 12](#) for this portion of the procedure. The new parts referenced in this procedure are listed in [Table 1 on page 4](#).

Install the following cables (provided) **in the order listed**.

- Wire harness 8121-0966 A45 reference switch ① to A16 test set motherboard J31
- Wire harness 8121-0966 A46 reference switch ② to A16 test set motherboard J30
- W96 E8364-20127 A45 reference switch to A46 reference switch
- W97 E8364-20121 A46 reference switch to REFERENCE 1 SOURCE OUT
- W98 E8364-20123 A45 reference switch to REFERENCE 1 RCVR R1 IN
- W99 E8364-20154 A45 reference switch to A28 channel R1 mixer
- W95 E8364-20119 A46 reference switch to channel R1 detector
- W71 E8364-20155 REFERENCE 2 RCVR R2 IN to A29 channel R2 mixer

Figure 12 Cable Installation, Analyzers with Options UNL, 014, and 080

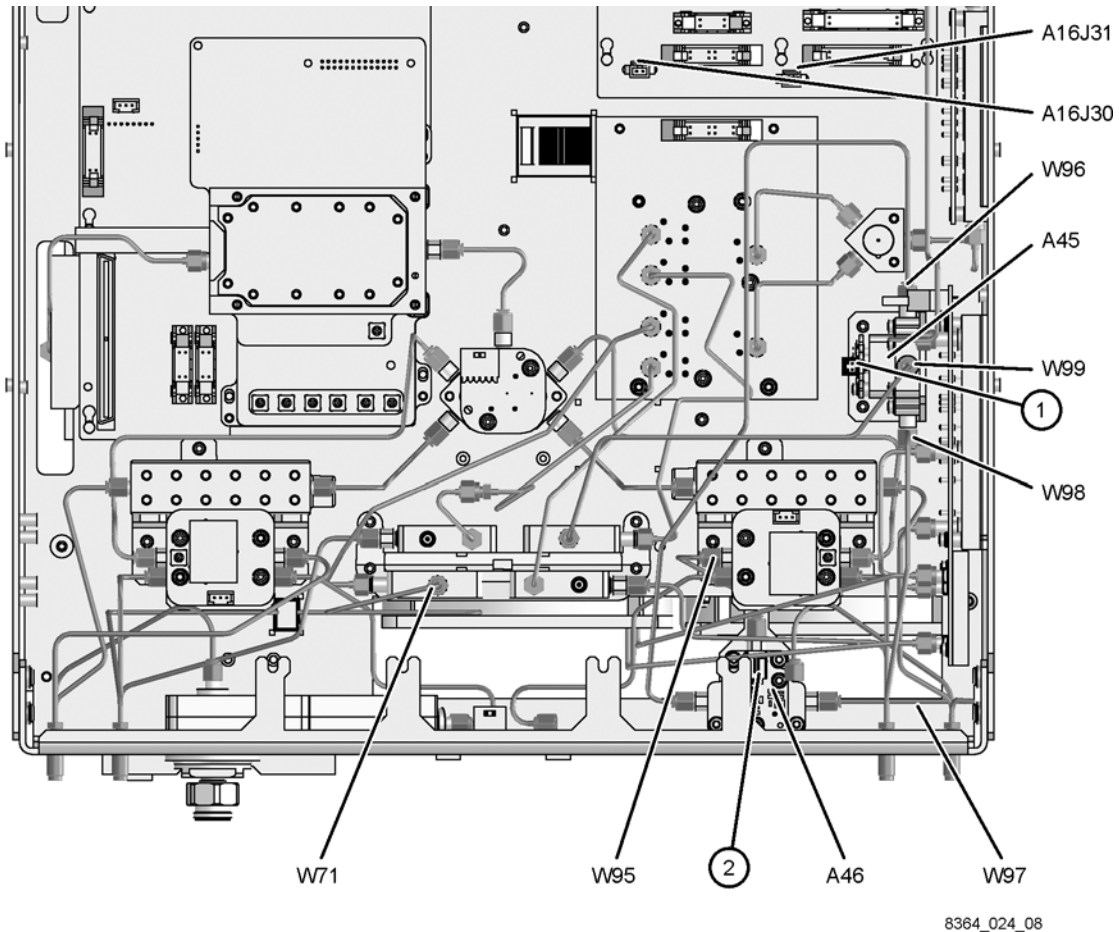

Analyzers with Hardware Options UNL, 014, 016, and 080

Refer to [Figure 13](#) for this portion of the procedure. The new parts referenced in this procedure are listed in [Table 1 on page 4](#).

Install the following cables (provided) **in the order listed**.

- Wire harness 8121-0966 A45 reference switch ① to A16 test set motherboard J31
- Wire harness 8121-0966 A46 reference switch ② to A16 test set motherboard J30
- W96 E8364-20127 A45 reference switch to A46 reference switch
- W97 E8364-20121 A46 reference switch to REFERENCE 1 SOURCE OUT
- W98 E8364-20123 A45 reference switch to REFERENCE 1 RCVR R1 IN
- W99 E8364-20125 A45 reference switch to A28 channel R1 mixer
- W95 E8364-20119 A46 reference switch to channel R1 detector

Figure 13 Cable Installation, Analyzers with Options UNL, 014, 016, and 080

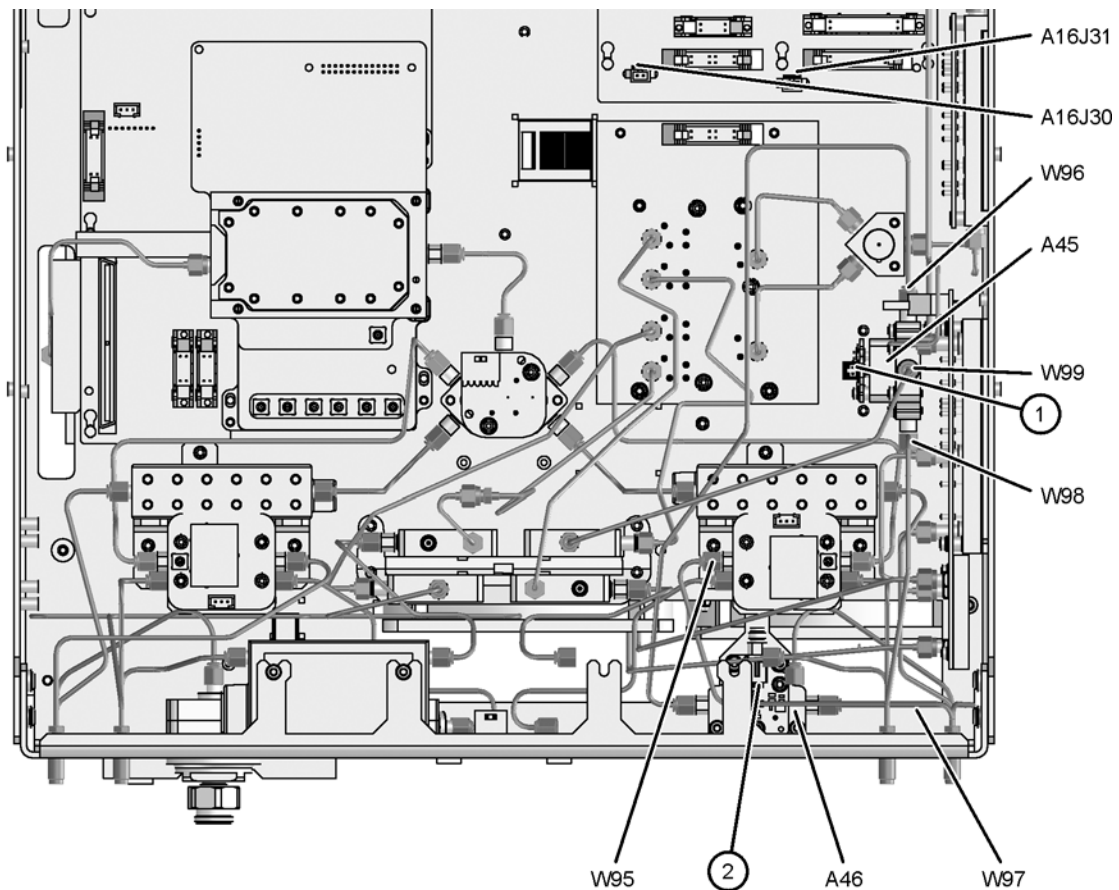

8364_024_09

Step 8. Reinstall the Test Port 1 Coupler and the Receiver Attenuator

Refer to [Figure 14](#) for this procedure.

1. Reinstall the A25 test port 1 coupler:
 - a. Place the test port coupler into position in the analyzer.
 - b. Using a 1-inch torque wrench reinstall the coupler nut (item ⑥).
 - c. Using a 5/16-inch torque wrench, reconnect the semirigid cable (item ④) to the coupler.
2. For analyzers with only hardware Options 014 and 080 combined, install the following new cable (item ⑤):
 - W67 E8364-20156 A25 test port 1 coupler to front panel PORT 1 CPLR ARM
3. Option 016 only. Reinstall the A43 channel A receiver attenuator:
 - a. Reconnect the ribbon cable to the attenuator and slide the attenuator into position in the mounting tabs.
 - b. With a T-10 TORX driver, tighten the two mounting screws (item ③) to secure the attenuator.
 - c. Using a 5/16-inch torque wrench, reconnect the semirigid cables (item ①) and (item ②).

Figure 14 Test Port Coupler and Receiver Attenuator Reinstallation

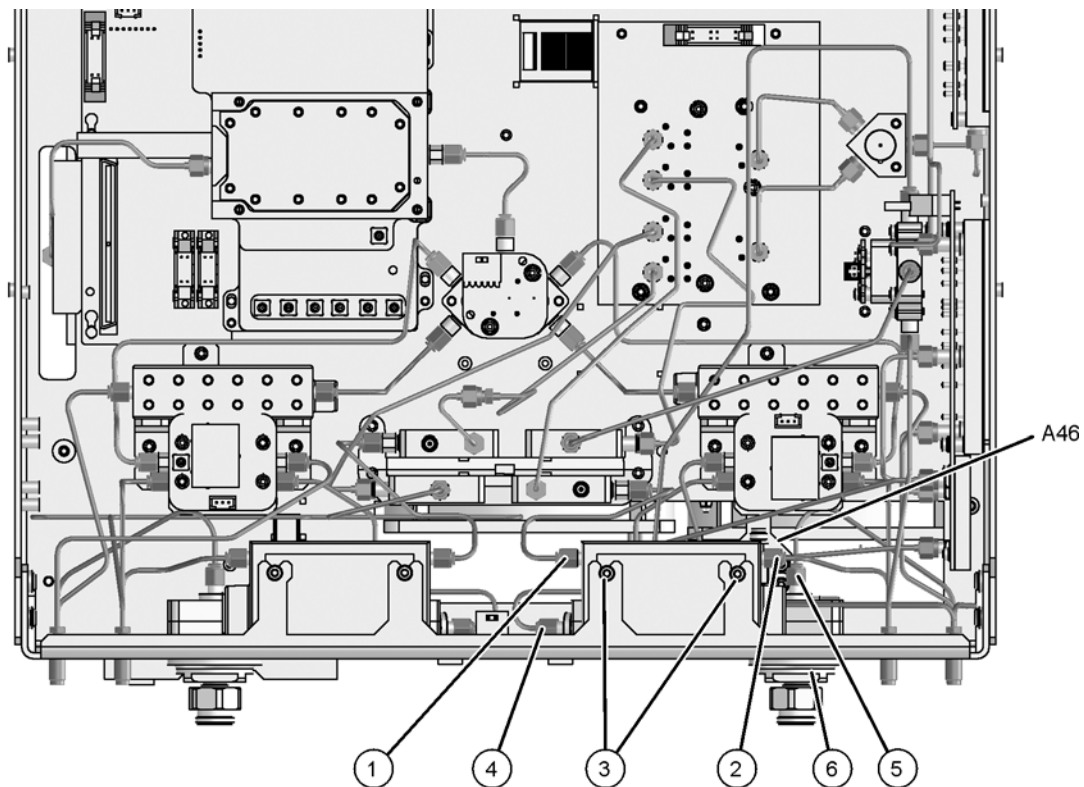

8364_024_10

Step 9. Lower and Secure the Receiver Deck

Refer to [Figure 15](#) for this procedure.

1. Pull the latch pin (item ②) towards the other side of the analyzer to release the receiver deck.
2. Lift the receiver deck to partially lower it, then release the latch pin (item ②). Lower the receiver deck to its fully lowered position and ensure that the latch pin latches in the lowered position.
3. With a T-10 TORX driver, install the four screws (item ①) to secure the receiver deck.

Figure 15 Receiver Deck Lowering

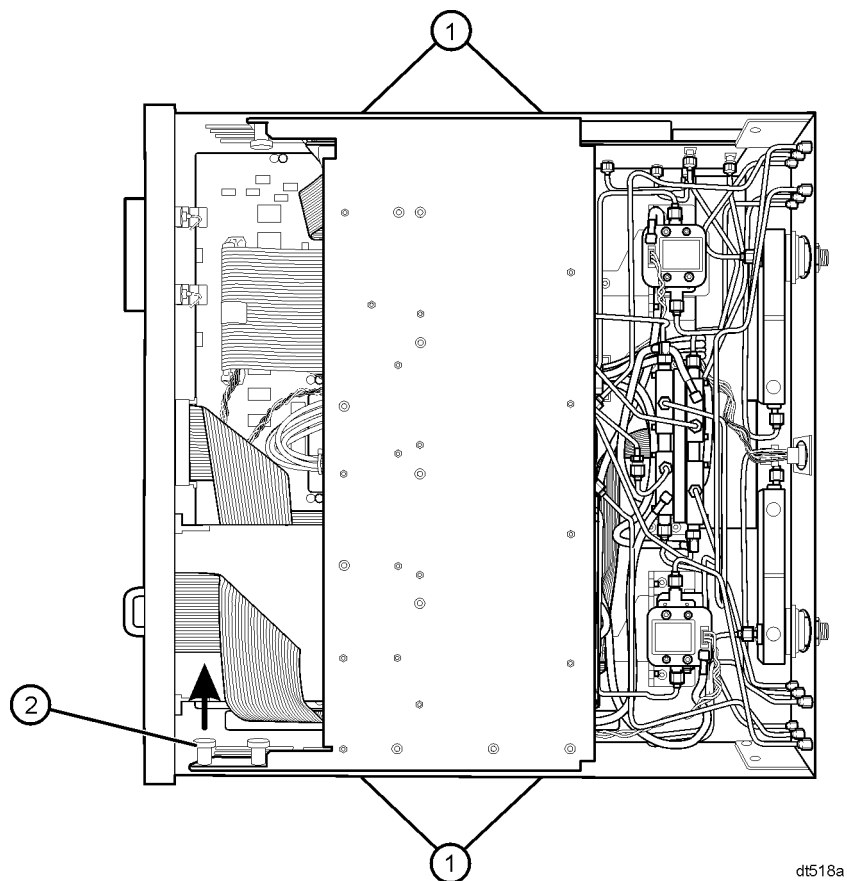

Step 10. Reinstall the Front Panel Assembly and Front Panel Jumpers

CAUTION Before installing the front panel assembly onto the analyzer, lift and support the front of the analyzer chassis.

Refer to [Figure 16](#) for this procedure.

1. Tighten all 12 of the front-panel feed-through connectors using a 5/16-inch torque wrench set to 21-inch lbs.
2. Reconnect the ribbon cable (item ③) to the A3 front panel interface board.
3. Slide the front panel over the test port connectors being careful to align the power switch and floppy disk drive to their corresponding front panel cutouts. Ensure that the ribbon cable (item ③) is located below the fan to prevent it from being damaged by the fan blades.
4. With a T-10 TORX driver, install the eight screws (item ②) in the sides of the frame.
5. Install the six semirigid jumpers (item ①) on the front panel and tighten to 10-inch lbs.

Figure 16 Front Panel Assembly Reinstallation

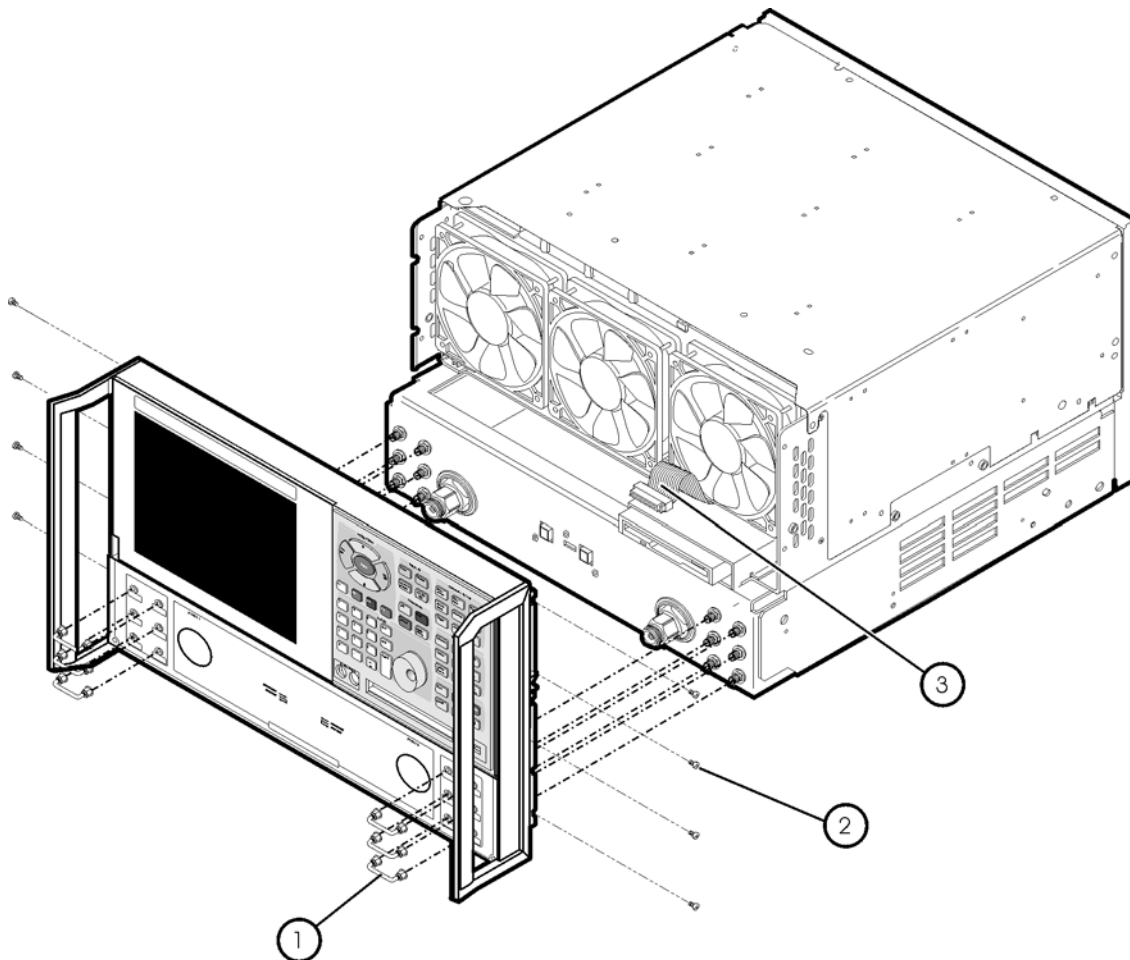

st536a

Step 11. Reinstall the Outer Cover

CAUTION This procedure is best performed with the analyzer resting on its front handles in the vertical position. *Do not place the analyzer on its front panel without the handles.* This will damage the front panel assemblies.

Refer to [Figure 17](#) for this procedure.

1. Slide the cover over the analyzer frame.
2. With a T-20 TORX driver, install the four rear panel feet (item ①) by installing the center screws (item ②).
3. Slide the four bottom feet (item ③) into position on the cover.
4. With a T-20 TORX driver, install the strap handles (item ④) by installing the screw (item ⑤) on each end of the handle.

Figure 17 Outer Cover Reinstallation

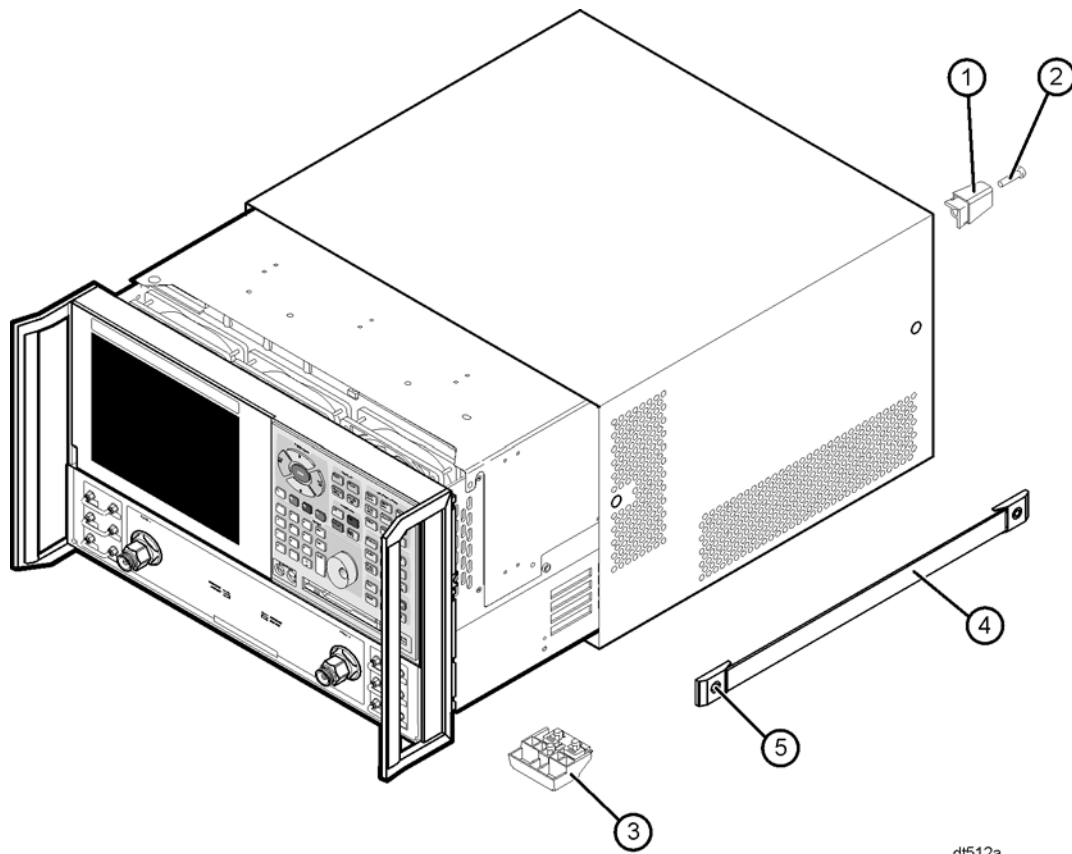

dt512a

Step 12. Enable Option 081

Procedure Requirements

- The analyzer must be powered up and operating to perform this procedure.
- The Network Analyzer program must be running.
- A mouse is required.

Enable Option 081

1. On the analyzer's **System** menu, point to **Service**, and then click **Option Enable**.
2. In the **Select Desired Option** list, click **081 - Reference Transfer Switch**.
3. Click **Enable**.
4. Click **Yes** in answer to the displayed question in the **Restart Analyzer?** box.
5. When the installation is complete, click **Exit**.

Verify that Option 081 is Enabled

1. On the analyzer's **Help** menu, click **About Network Analyzer**.
2. Verify that "081" is listed after "Options:" in the display.
3. Click **OK** when done.

NOTE If Option 081 has not been enabled, perform "[Enable Option 081](#)" again. If the option is still not enabled, contact Agilent Technologies. Refer to "[Contacting Agilent](#)" on page 3.

Step 13. Perform Post-Upgrade Adjustments and Calibration

The following adjustments must be made due to the change in the full frequency range of the analyzer.

- source calibration
- receiver calibration

These adjustments are described in the PNA service guide and in the PNA on-line HELP. A list of equipment required to perform these adjustments can be found at [“Equipment Required for Post-Upgrade Adjustments” on page 6.](#)

Performance Tests and System Verification

The analyzer should now operate and phase lock over its entire frequency range.

If you experience difficulty with the basic functioning of the analyzer, contact Agilent. Refer to [“Contacting Agilent” on page 3.](#)

Although the analyzer functions, its performance relative to its specifications has not been verified for the additional frequency range enabled by this upgrade.

It is recommended that a full instrument calibration be performed using the PNA performance test software.

If the testing of the analyzer’s full range of specifications is not required, a system verification can be performed.

Refer to the analyzer’s service guide for information on performance tests and system verification.